



SHUTTLE 100

Tubular Suspended Pendant

MANUFACTURING IN THE UNITED KINGDOM

- Laser cut steel construction
- Passive aluminium heat sink
- Tridonic LED modules and drivers
- Supplied with adjustable 3m drop wire suspension kit
- Downlight only
- Small colour tolerance
- Surface mounting option available
- 3 step MacAdam CRI 80/90/95
- 2 step MacAdam CRI97
- Bespoke/project specific sizes and outputs made to order
- Various powder coating finishes
- Xicato LED available
- IP20 rated
- Wireless option available
- 5 year warranty on LED system

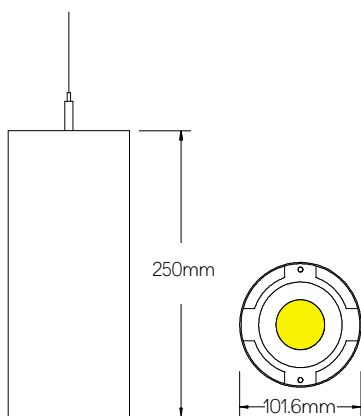

Ambient operating temperature 25°C

PRODUCT CODE		
Product	ST10	Shuttle Pendant
Mounting	SP	Wire suspended
	SF	Surface
Driver	S	Standard Driver
	D	Dali Driver
	W	Wireless Dim
	A	1-10V Driver*
Output	T	Touch Dimming Driver
	10	1000 Lumens
	15	1500 Lumens
	20	2000 Lumens
Colour Temperature	25	2500 Lumens
	3	3000 Kelvin
Colour Rendering	4	4000 Kelvin
	S	Ra80
	N	Ra90
Beam Angle	F	Ra95 Fashion**
	A	Ra97 Art***
Body Colour	20	20° Twist-lock Reflector
	40	40° Twist-lock Reflector
	60	60° Twist-lock Reflector
Cable Colour	W	White
	B	Black
	S	Silver
	O	Other/Specified
Beam Angle	W	White PVC
	B	Black PVC
	G	Grey PVC
	T	Transparent

* Not available in all outputs
** 3250K only
*** 3000K only

