



## SHUTTLE 150

### Tubular Suspended Pendant

MANUFACTURING IN THE  
UNITED KINGDOM

- Laser cut steel construction
- Passive aluminium heat sink
- Tridonic LED modules and drivers
- Supplied with adjustable 3m drop wire suspension kit
- Downlight only
- Small colour tolerance
- Surface mounting option available
- 3 step MacAdam CRI 80/90/95
- 2 step MacAdam CRI 97
- Bespoke/project specific sizes and outputs made to order
- Various powder coating finishes
- Xicato LED available
- IP20 rated
- Wireless option available
- 5 year warranty on LED system

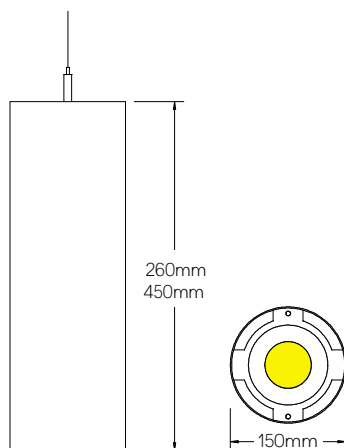

Ambient operating temperature 25°C

PRODUCT CODE		
<b>Product</b>	ST15	Shuttle Pendant
<b>Mounting</b>	SP	Wire suspended
	SF	Surface
<b>Body Size</b>	2	260mm
	4	450mm
<b>Driver</b>	S	Standard Driver
	D	Dali Driver
	W	Wireless Dim
	A	1-10V Driver*
	T	Touch Dimming Driver
<b>Output (260mm)</b>	10	1000 Lumens
	20	2000 Lumens
<b>Output (450mm)</b>	10	1000 Lumens
	20	2000 Lumens
	30	3000 Lumens
	40	4000 Lumens
	50	5000 Lumens
<b>Colour Temperature</b>	3	3000 Kelvin
	4	4000 Kelvin
<b>Colour Rendering</b>	S	Ra80
	N	Ra90
	F	Ra95 Fashion**
	A	Ra97 Art***
<b>Beam Angle</b>	10	10° Twist-lock Reflector
	30	30° Twist-lock Reflector
	45	45° Twist-lock Reflector
<b>Body Colour</b>	W	White
	B	Black
	S	Silver
	O	Other/Specified
<b>Cable Colour</b>	W	White PVC
	B	Black PVC
	G	Grey PVC
	T	Transparent

\* Not available in all outputs  
\*\* 3250K only  
\*\*\* 3000K only

