

## SATURN Bulkhead

MANUFACTURING IN THE  
**UNITED KINGDOM**

- Body and bezel constructed from polycarbonate
- TPa rated high transmission opal polycarbonate diffuser
- Tridonic LED modules and drivers
- Available with backlit halo effect
- Wall or ceiling mountable
- Available with tamper proof screws
- Wireless option available
- Optional LiFePO4 Lithium Battery for extended life
- IP65 rated
- IK10 rated
- 5 year warranty on LED system

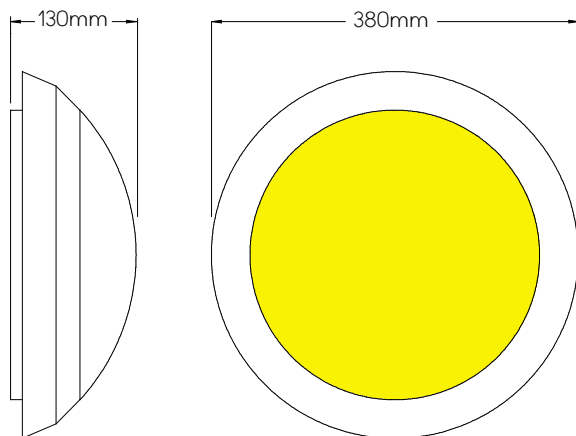

Ambient operating temperature 25°C

### PRODUCT CODE

<b>Product</b>	<b>SAT</b>	Saturn Bulkhead
<b>Halo</b>	<b>S</b>	Standard
	<b>H</b>	Halo Effect
<b>Driver</b>	<b>S</b>	Standard Driver
	<b>D</b>	Dali Driver
	<b>W</b>	Wireless Dim
	<b>A</b>	1-10V Driver
<b>Output</b>	<b>T</b>	Touch Dimming Driver
	<b>01</b>	1000 Lumens
	<b>02</b>	2000 Lumens
<b>Colour Temperature</b>	<b>03</b>	2600 Lumens
	<b>3</b>	3000 Kelvin
<b>Sensor</b>	<b>4</b>	4000 Kelvin
	<b>-</b>	No Sensor
<b>Emergency</b>	<b>MW</b>	Microwave Sensor
	<b>-</b>	No Emergency
	<b>EL</b>	3 Hour Emergency
	<b>ST</b>	Self-Test 3 Hour Emergency
	<b>ED</b>	3 Hour Emergency DALI EM Pro
<b>Body Colour</b>	<b>LM</b>	Lithium Emergency
	<b>W</b>	White
	<b>C</b>	Chrome
	<b>S</b>	Silver