

GLOBAL TRAC PRO

The Most Commonly Used 3-Circuit Track

- The modular structure of the system makes it easy to extend and adapt to various needs
- Suitable for various spaces including stores, department stores, public buildings, restaurants, airports and offices
- Recessed mounting version for suspended ceilings available on request
- The most popular three-phase lighting track system in the world
- Circuits can be controlled individually
- Easy to mount
- 100% quality assurance ensure problem free operation

Order Code	Length	Colour
XTS4100-2	1000mm	Black
XTS4100-3	1000mm	White
XTS4200-2	2000mm	Black
XTS4200-3	2000mm	White
XTS4300-2	3000mm	Black
XTS4300-3	3000mm	White
XTS4400-2	4000mm	Black
XTS4400-3	4000mm	White

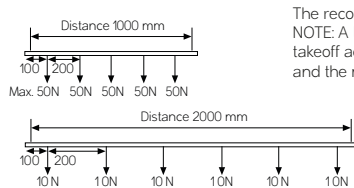
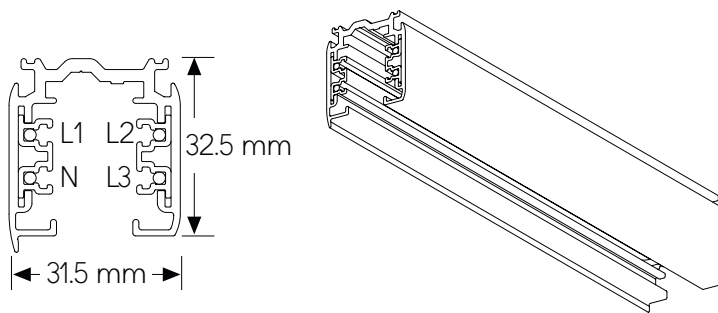

The recommended fastening distance is 1000 mm.
NOTE: A load no heavier than 10 kg may hang on a power takeoff adapter, the pull strength being 100 N (1kp = 9.81N) and the maximum torque 2.5 Nm. (GA 69.5 kg/50 N).