

BLOK

Surface or Suspended Linear

MANUFACTURING IN THE
UNITED KINGDOM

- Body constructed from powder coated steel
- High transmission opal diffuser
- Microprism diffuser available to aid in achieving UGR<19
- Tridonic or Philips LED modules and drivers
- Stand-alone or continuous run lighting system
- Downlight only or up/downlight
- High colour rendering CRI>80
- High colour consistency 3 step MacAdam
- Bespoke/project specific sizes, shapes and outputs made to order
- Corner section made to order
- Various powder coated finishes
- Infill blanking panels optional**
- IP20 rated
- Wireless option available
- Optional LiFePO4 Lithium Battery for extended life
- 5 year warranty on LED system

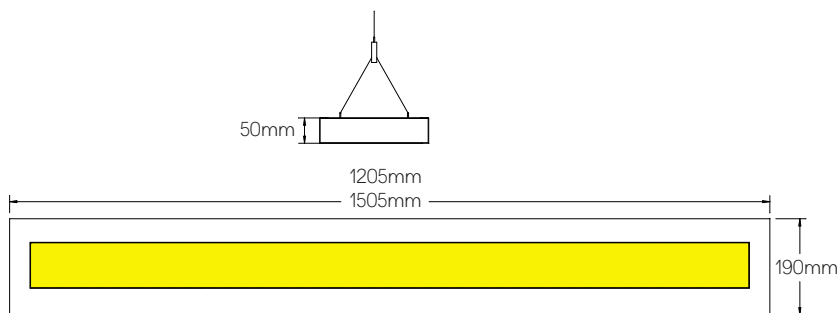

Ambient operating temperature 25°C

PRODUCT CODE	
Product	BL Blok Linear
Distribution	D Downlight Only
	U Uplight / Downlight
Mounting	SP Suspended Mount
	SF Surface Mount**
Body Size	12 Length (1205mm)
	15 Length (1505mm)
Configuration	SA Stand-alone
	CC Continuous Centre
	CS Continuous Start
	CE Continuous End
Driver	S Standard Driver
	D Dali Driver
	W Wireless Dim
	A 1-10V Driver
	T Touch Dimming Driver
Output (1205mm)	04 4000 Lumens
	06 6000 Lumens
	07 7000 Lumens
Output (1505mm)	08 8000 Lumens
	06 6000 Lumens
	08 8000 Lumens
	09 9000 Lumens
Colour Temperature	3 3000 Kelvin
	4 4000 Kelvin
Sensor	- No Sensor
	MS Mini Sensor
Emergency	- No Emergency
	EL 3 Hour Emergency
	ST Self-Test 3 Hour Emergency
	ED 3 Hour Emergency DALI EM Pro
	LM Lithium Emergency
Diffuser	OP Opal
	MP Microprism
Body Colour	W White
	B Black
	S Silver
	G Gold
	O Other/Specified

**Surface mount diffusers and infill blanking panels are lift and tilt mounting

